

ENGINEERING
YOUR SPRAY SOLUTION



Air nozzles

Air curtains
Blowing off and out
Cleaning
Cooling
Drying
Reheating
Transporting
and many others...

Air nozzles



As a rule, any flat fan or solid stream nozzle can be operated with air instead of liquid. However, you'll obtain the best results using the nozzle designs we specially engineered for applications of compressed air or saturated steam. For further details, please refer to the next pages.

In addition to air, various nozzle types are also suited for injecting saturated steam. Typical applications of Lechler air nozzles are, for instance, efficient blowing off and blowing out, cooling, drying or cleaning.

Multi-channel air nozzles

In many industries and workshops compressed air has become an indispensable tool. Compressed air is needed for cleaning, blowing off, drying, conveying and for numerous other applications. Where uncontrolled compressed air is applied, very often annoying, high-frequency hiss noises arise, which may cause serious harm to hearing. These »noises« are produced by turbulences generated at the air outlet. Their intensity depends on the shape of the nozzle orifice and on the air pressure.

This means: the better and stronger the air jet is supposed to be, the higher the health-injuring noise level and the higher the air consumption and its cost.

The solution: Lechler multi-channel air nozzles, featuring a significantly reduced sound level, high blowing power and low air consumption.

The performance of multi-channel air nozzles is based on partitioning the air inflow into single air jets. 16 air channels, arranged to ensure optimum flow conditions, provide for a particularly uniform, straight and powerful overall air jet.



In comparison to single-hole air nozzles the advantages are as follows:

- Reduction of the noise level of up to 12 dB
- Low service air pressure with the same blowing power
- Lower air consumption
- Better blowing effect over a longer reach
- Lower operating costs

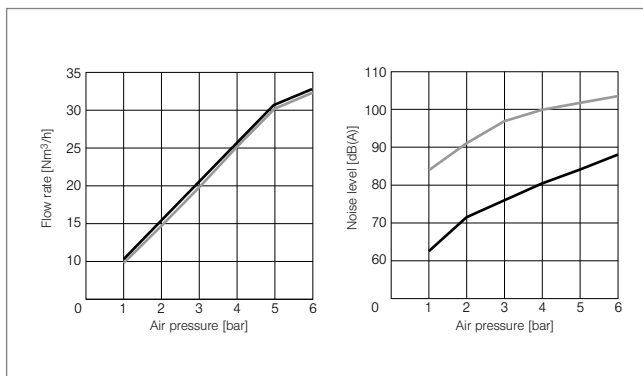
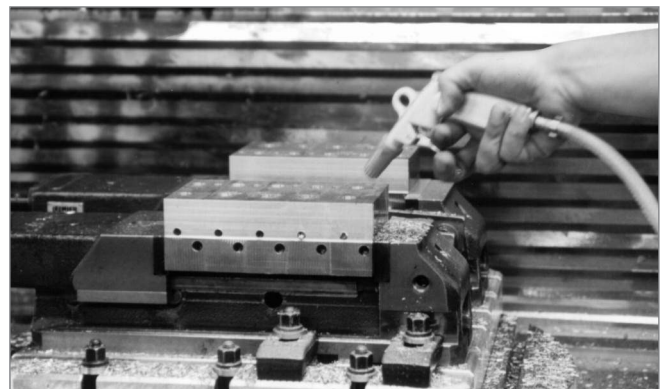

Comparison of a conventional, single-hole nozzle with the Lechler multi-channel round jet nozzle type 600.326







- Lechler multi-channel round jet nozzle
- Conventional single-hole nozzle

Note for calculation of measuring values:

Blowing power: Blowing distance vertical 50 mm on a scale, area 400 x 500 mm.



Air nozzles





Flat fan nozzles for Air	Series		Air consumption [m ³ /h] at p = 2 bar	Connection	Application/Design	Page
	600.130 600.484	PARTICULARLY SILENT	8.00 - 18.00	1/4 BSPP 1/4 BSPP NPT 1/4 M 12 x 1.25 Quick release cuppling NW5	Blowing off and blowing out, cleaning, drying, cooling, conveying with air. Multi-channel flat fan nozzle. Plastic versions.	6.5
	600.283 600.493 600.562		7.50 - 30.00	1/8 BSPP 1/4 BSPP 1/4 NPT	Blowing off and blowing out, cleaning, drying, cooling, conveying with air. Multi-channel flat fan nozzle. Metallic versions.	6.6
 	679		2.60 - 32.80	Assembly with 3/8" lock nut	Blowing off liquids, cooling, reheating, drying. Easy nozzle changing. Simple jet alignment.	6.7
	686		1.00 - 16.00	1/8 BSPT	Blowing off liquids, cooling, reheating, drying. Tongue-type nozzle.	6.8

For more information please ask for our special brochure »Nozzles and Accessories for Compressed Air«.





Air nozzles

Solid stream nozzles for air	Series		Air consumption [m ³ /h] at $p = 2$ bar	Connection	Application/Design	Page
 <div data-bbox="379 645 539 734" style="transform: rotate(-15deg); border: 1px solid black; padding: 2px; font-weight: bold;">PARTICULARLY SILENT</div>	600.326		15.00	1/4 BSPP M 12 x 1.25	Targeted blowing out and blowing off with the aid of air guns. Multi-channel round jet nozzle, producing a powerful air jet with punctiform impact pattern.	6.9
	600.388		8.60	1/8 BSPP M 12 x 1.25	Targeted blowing out and blowing off with the aid of air guns. Multi-channel round jet nozzle. Compact design. Especially for blowing out of pocket holes.	6.9
	544		1.00 – 16.00	1/8 BSPT 1/4 BSPT	Targeted blowing out and blowing off. Powerful air jet with punctiform impact pattern.	6.10
	540 541	240°	39.30 – 325.00	1/2 BSPP	Injection of steam into liquids, injection of compressed air into bulk goods, gas injection. Multi-channel solid stream nozzle.	6.11



For more information please ask for our special brochure »Nozzles and Accessories for Compressed Air«.



Multi-channel flat fan nozzles for air
Whisperblast®, Plastic versions
Series 600. 130 / 600. 484

**Particularly
 silent !**

NEW!
 Also available in PP for
 galvanic and food
 industry (FDA-
 conform material)

**Highly efficient air stream,
 acting upon areas. Reduced
 noise levels. Low air con-
 sumption.**

Applications:
 Blowing off and blowing out,
 cleaning, drying, cooling, con-
 veying with air.



600. 130 (POM or PP)



600. 484. 56 (POM)

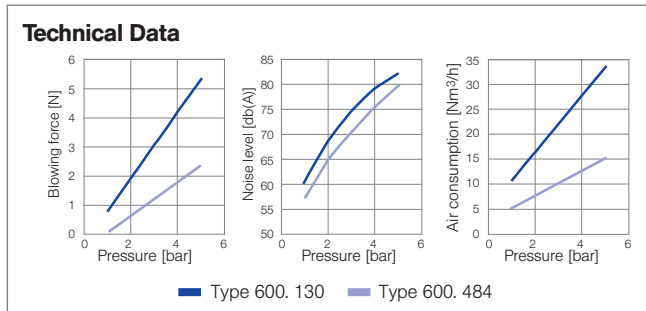
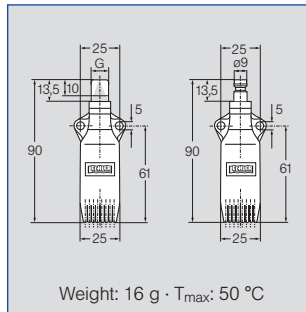
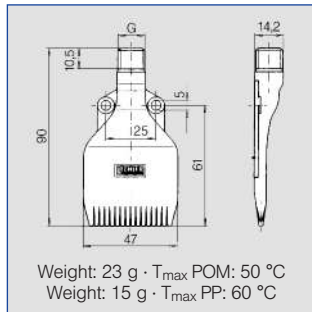

Socket
Ordering no.
095.016.30.14.23.0

Material: Brass

For connection of series
 600.130 with compressed air
 guns.



Ball joints see page 9.8

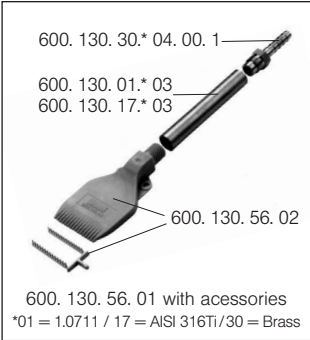

**For more information please
 ask for our special brochure
 »Nozzles and Accessories for
 Compressed
 Air«.**



Ordering no.						
Type	Material no.		Code			
	S2	56				
	PP	POM	1/4 BSPP	1/4 NPT	M12 x 1.25	Quick connection NW 5
600. 130	○	○	AC	BC	-	-
600. 130 with plug	-	○	02	-	-	-
600. 130 with plug, hose barb (D = 8 mm) and extension tube, steel (L = 85 mm)	-	○	01	-	-	-
600. 484	-	○	AC	BC	HG	00

Example Type + Material no. + Code = Ordering no.
for ordering: 600. 130. + 56. + AC = 600. 130. 56. AC





Multi-channel flat fan nozzles for air
Whisperblast®, metallic versions
Series 600. 283 / 600. 493 / 600. 562

Particularly silent !

Metallic versions for higher temperatures. Highly efficient air stream, acting upon areas. Reduced noise levels. Low air consumption.

Applications:
 Blowing off and blowing out, cleaning, drying, cooling, conveying with air.



600. 283. 42 (Aluminium)



600. 493. 1Y (Stainless steel 316L)



600. 562. 1Y. 10 (Stainless steel 316L)



1/4 BSPP

M 12 x 1.25

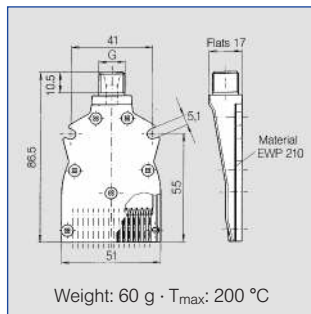

Weight: 60 g · T_{max}: 200 °C

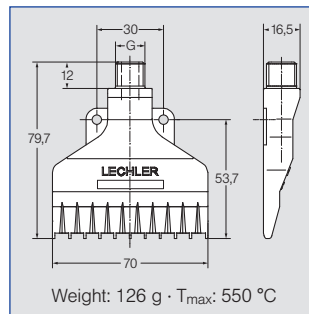

Weight: 126 g · T_{max}: 550 °C

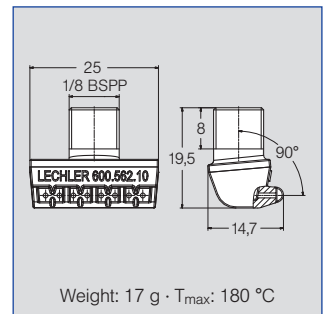

Weight: 17 g · T_{max}: 180 °C

Socket
Ordering no.
095.016.30.14.23.0

Material: Brass

For connection with compressed air guns for the following series:

- 600. 283
- 600. 493

Technical data

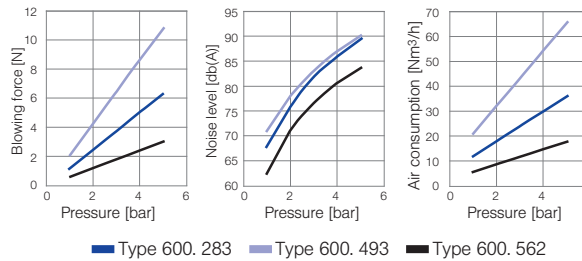

Ordering no.					
Type	Material-no.		Code		
	42	1Y			
	Aluminium	Stainless steel	1/8 BSPP	1/4 BSPP	1/4 NPT
600. 283	○	-	-	AC	BC
600. 493	-	○	-	AC	BC
600. 562. 1Y. 10	-	○	○	-	-

Example **Type** + **Material no.** + **Code** = **Ordering no.**
 for ordering: 600. 283. + 42. + AC = 600. 283. 42. AC

For more information please ask for our special brochure »Nozzles and Accessories for Compressed Air«.



Ball joints see page 9.8



Flat fan nozzles for air or saturated steam

Series 679

Particularly wide-angle, powerful air jet. Assembling with retaining nut. Easy nozzle changing. Simple jet alignment.

Applications:
Blowing off liquids, cooling, reheating, drying.

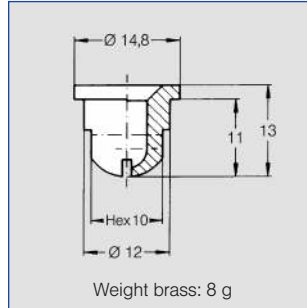

For assembling possibilities please refer to folded page.

Spray angle	Ordering no.		A Ø [mm]	\dot{V}_n L = Air [m ³ /h] \dot{M} S = Saturated Steam [kg/h]											
	Type	Mat.-no.		p [bar]											
		17	30	0.5		2.0		5.0		10.0					
ca. 70°		316Ti SS	Brass	L	S	L	S	L	S	L	S	L	S		
	679. 037	-	○	1.2	1.50	1.20	3.00	2.30	6.00	4.60	11.00	8.30			
	679. 085	○	○	1.3	2.00	1.60	4.00	3.10	8.00	6.10	14.70	11.10			
	679. 117	○	○	1.5	2.10	1.70	4.20	3.30	8.40	6.50	15.40	11.70			
	679. 165	○	○	1.8	2.60	2.00	5.10	4.10	10.30	8.00	18.80	14.30			
	679. 255	○	○	2.1	3.60	2.80	7.30	5.70	14.50	11.20	26.60	20.20			
	679. 365	○	○	2.8	6.30	5.00	12.70	10.00	25.40	19.60	46.50	35.30			
	679. 415	○	○	3.6	10.20	8.00	20.30	16.00	40.70	31.40	74.60	56.70			
	679. 495	○	○	4.3	15.60	12.40	31.10	24.80	62.20	48.50	114.00	87.60			

A = Equivalent bore diameter

The folded page at the end of the catalogue will give you a survey on the various assembly possibilities.

For complete assembly accessories, please refer to »Accessories«.

Example for ordering:	Type	+	Material no.	=	Ordering no.
	679. 037	+	30	=	679. 037. 30

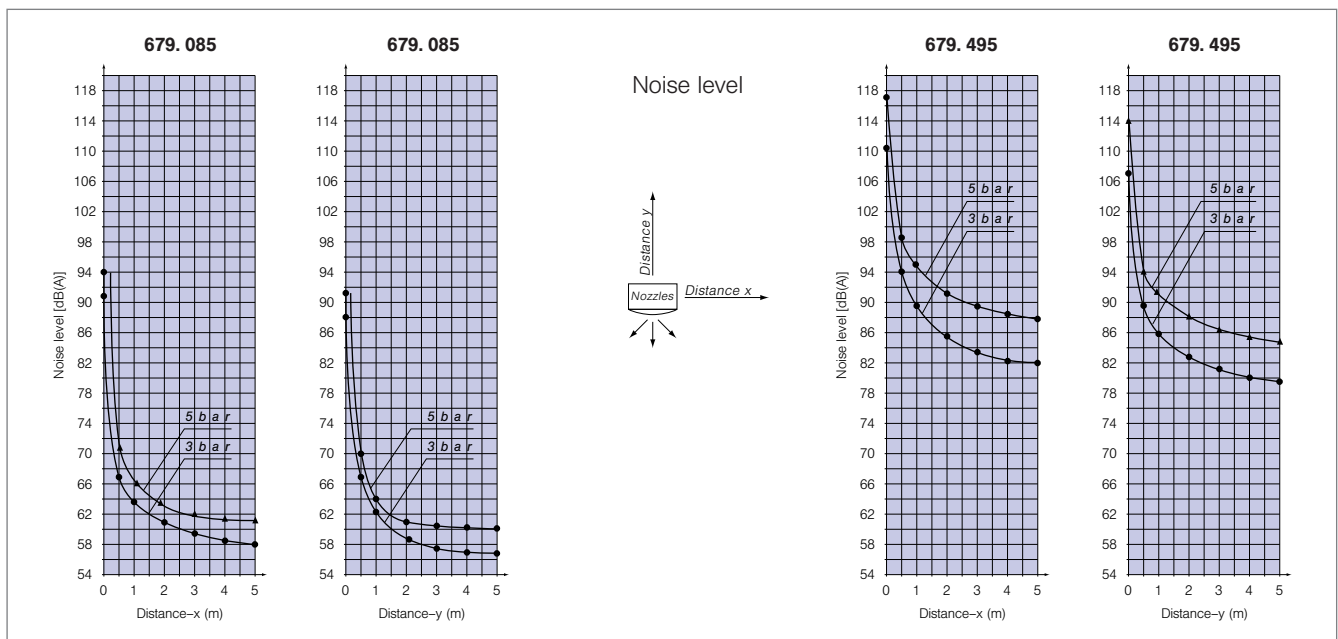



Tongue-type nozzles for air or saturated steam

Series 686

Wide-angle, powerful air jet.

Applications:
Blowing off liquids, cooling,
reheating, drying.

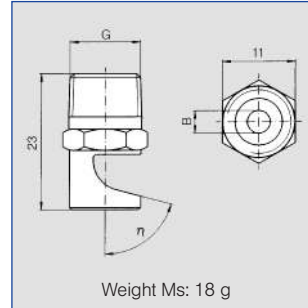

★ Spray angle	Ordering no.				B [mm]	η	V̇ _n Air [m ³ /h]				Ṁ Saturated steam [kg/h]			
	Type	Mat.-no.		Code			p [bar]				p [bar]			
		16	30				1.0	2.0	5.0	10.0	1.0	2.0	5.0	10.0
		303 SS	Brass	1/8 BSPT										
ca. 70°	686. 408	○	○	CA	1.0	75°	1.07	1.60	3.20	5.86	0.88	1.31	2.57	4.64
	686. 488	○	○	CA	1.3	75°	1.76	2.64	5.29	9.69	1.46	2.17	4.25	7.67
	686. 528	○	○	CA	1.5	75°	2.20	3.31	6.61	12.13	1.83	2.71	5.31	9.59
	686. 568	○	○	CA	1.7	75°	2.73	4.09	8.19	15.01	2.27	3.36	6.57	11.87
	686. 608	○	○	CA	1.9	75°	3.35	5.02	10.04	18.40	2.78	4.11	8.06	14.55
	686. 688	○	○	CA	2.4	75°	5.45	8.18	16.36	30.00	4.53	6.71	13.14	23.72
	686. 728	○	○	CA	2.7	75°	6.88	10.33	20.65	37.86	5.71	8.46	16.58	29.94
	686. 808	○	○	CA	3.4	75°	10.89	16.33	32.66	59.87	9.04	13.28	26.22	47.35

B = bore diameter

The folded page at the end of the catalogue will give you a survey on the various assembly possibilities. For complete assembly accessories, please refer to »Accessories«.

Example Type + Material no. + Code = Ordering no.
for Ordering: 684. 408 + 16 + CA = 684. 408. 16. CA



Ball joints see page 9.8



Multi-channel round jet nozzles for air

Series 600. 326 / 600.388

Particularly silent !

Powerful air jet, producing punctiform impact patterns. Low noise level. Low air consumption.

Applications:
Targeted blowing out and blowing off with compressed air guns.

Reduction of noise level of up to 12 dB (A).

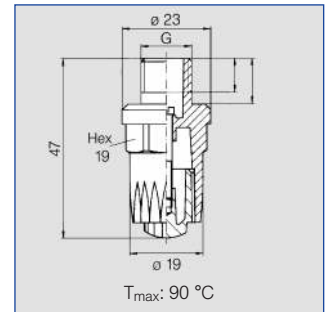
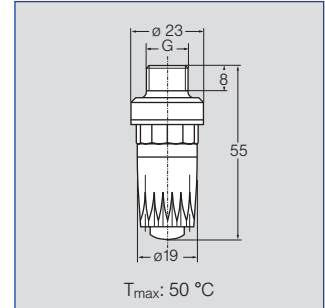

Mini-round jet nozzle. Compact design

Applications:
Especially for blowing out pocket holes.

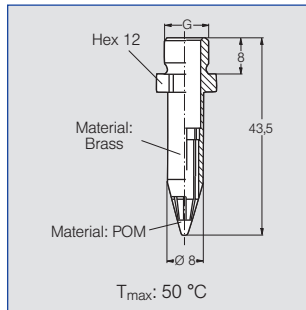

Ball joints see page 9.8

Ordering no.		Code	Connection thread G	Weight
Type				
600. 326. 5K (Material: ABS)	AC		1/4 BSPP	9 g
	HG		M 12 x 1.25	
600. 326. 3W (Material: Zinc)	AC		1/4 BSPP	47 g
	HG		M 12 x 1.25	
600. 388. 30 (Material: Brass/POM)	AA		1/8 BSPP	12 g
	HG		M 12 x 1.25	

Example: Type 600. 326. 5K + Code AC = Ordering no. 600. 326. 5K. AC
for ordering

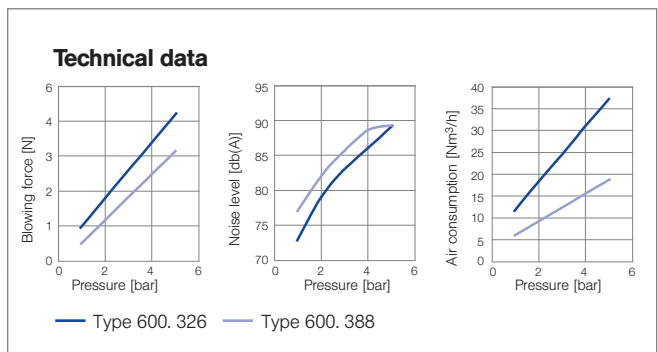



Solid stream nozzles for air or saturated steam

Series 544

Powerful air jet, producing punctiform impact patterns.

Applications:
Targeted blowing out and blowing off.



Series 544.360 to 544.400



Series 544.480 to 544.800

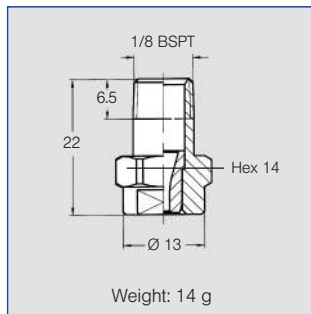

Weight: 14 g

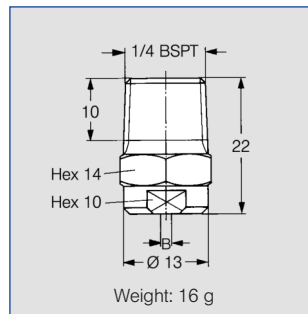

Weight: 16 g

Ordering no.		B Ø [mm]	\dot{V}_n Air [m ³ /h]				\dot{M} Saturated steam [kg/h]					
Type	Mat.-no.		Code		p [bar]							
	16		303 SS	1/8 BSPT	1/4 BSPT	1	2	3	5	1	2	3
544.360	●	CA	CC	1.05	0,93	1,40	1,92	2,88	0,77	1,14	1,64	2,42
544.400	●	CA	CC	1.30	1,43	2,14	2,94	4,41	1,18	1,75	2,51	3,71
544.480	●	CA	CC	1.33	1,67	2,51	3,42	5,13	1,39	2,06	2,92	4,23
544.560	●	CA	CC	1.69	2,58	3,87	5,27	7,90	2,14	3,18	4,50	6,66
544.640	●	CA	CC	2.09	4,33	6,50	8,81	13,22	3,60	5,33	7,52	11,13
544.720	●	CA	CC	2.66	6,85	10,27	14,00	21,02	5,68	8,42	11,96	17,70
544.800	●	CA	CC	3.30	10,75	16,12	21,87	32,81	8,92	13,21	18,66	27,63

B = bore diameter

Example for ordering: Type + Material no. + Code = Ordering no.
544.360 + 16 + CC = 544.360.16.CC



Ball joints see page 9.8



Cluster solid stream nozzles for air or saturated steam

Series 540 / 541

Powerful air jet with 40 individual bore holes.

Applications:

Injection of steam into liquids, injection of compressed air into bulk goods, gas injection (acid and neutralization baths).

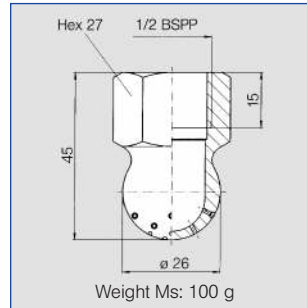

 Spray angle	Ordering no.		B ∅ [mm]	\dot{V}_n Air [m ³ /h]				\dot{M} Saturated steam [kg/h]			
	Type	Mat- no. 16		p [bar]				p [bar]			
				1.0	2.0	3.0	5.0	1.0	2.0	3.0	5.0
ca. 240°	540. 909	○	0.8	22.80	34.20	45.50	68.30	18.10	26.90	35.50	52.70
	540. 989	○	1.0	35.50	53.30	71.00	106.50	28.20	41.70	55.10	81.70
	541. 109	○	1.5	83.30	124.90	166.50	249.80	66.00	97.70	129.20	191.60
	541. 189	○	2.0	129.70	194.50	259.30	389.00	103.00	152.60	201.70	299.10
	541. 239	○	2.3	167.20	250.80	334.30	501.50	133.20	197.30	260.80	386.60

B = bore diameter

Example	Type	+	Material no.	=	Ordering no.
for ordering:	540. 909	+	16	=	540. 909. 16